

Angle Valves

Type 01322 - Globe Valve Angle Type



Cryogenic-Globe Valves Angle Type, PN50

Stainless steel body and bronze topwork
 "live loaded" gland packing
 "cleaned and degreased for oxygen service"

Part No. 01322.X.001* (H = 270mm)

Part No. 01322.X.002* (H = 370mm)

* Butt weld connection for stainless steel pipes acc. to ISO 1127 or ASTM A312

Part No. 01322.X.0014 (H = 270mm)

Part No. 01322.X.0024 (H = 370mm)

Socket weld connection for stainless steel pipes acc. to ISO 1127 or ASTM A312

Available options - on request only:

- Extension H up to 900mm
- Valve with control disc (tapered design)
- Valve with check disc
- Further pipe wall thicknesses



Applications:

Approved for air gases, vapours and cryogenic liquefied gases incl. LNG.

Working temperature: -196°C / -321°F (77K) up to +120°C / +248°F (393K)

Materials	DIN EN	ASTM
1 Body	1.4308	A 351 CF8
2 Valve seal	PTFE / Carbon filled (25%)	
3 Disc	CW614N	B 283 UNS C38500
4 Bonnet gasket	PTFE	
5 Headpieceflansch	CC493K	B 505 UNS C93200
6 Bolts	1.4301/A2	A 194 B8
7 Elongation tube	1.4541	A 213 TP 321
8 Stem	1.4301	A 276 Grade 304
9 Gland packing	Graphite / PTFE	
10 Gland nut	CW614N	B 283 UNS C38500
11 Handwheel	Aluminium alloy	

Standard marking acc. to Pressure Equipment Directive 2014/68/EU (PED).

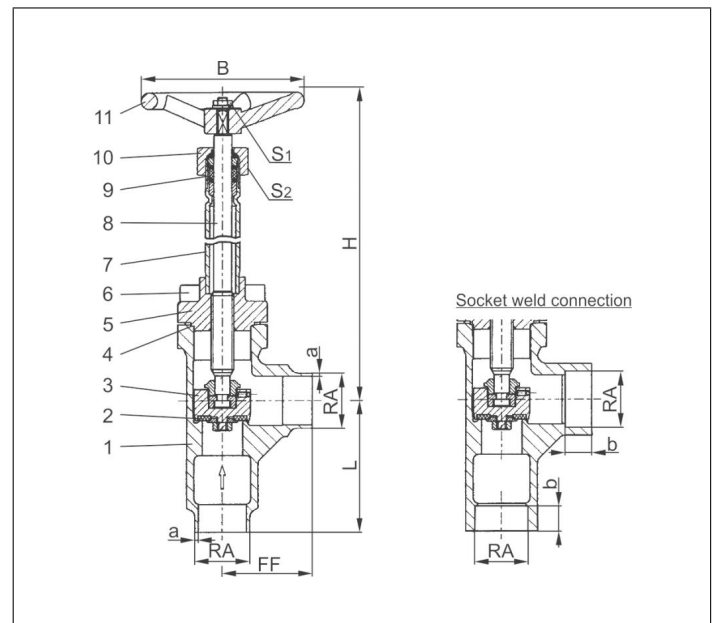

Type 01322 - Standard design	Technical data						
Nominal size	DN	15	20	25	32	40	50
Dimension code	.X.	1521	2026	2533	3242	4048	5060
Face-to-face dimension	FF	40	50	55	60	58	85
Height	H	270mm or 370mm					
Outside pipe-Ø ISO 1127	RA	21.3	26.9	33.7	42.0	48.3	60.3
Wall thickness pipe ISO 1127	a	2.0	2.0	2.0	2.0	2.0	2.0
Outside pipe-Ø ASTM A312	RA	21.34	26.67	33.40	-	48.26	60.33
Wall thickness pipe ASTM A312	a	dimensions acc. to S10 or S40					
Socket depth	b	10	13	13	13	13	16
Handwheel-Ø	B	100	100	100	125	125	125
Length	L	50	65	80	80	90	90
Wrench size across flats	S ₁	10	10	10	13	13	13
Wrench size across flats	S ₂	30	30	30	36	36	36
Weight	ca. kg	1.4	1.6	2.2	4.0	4.3	6.5
Kvs-Value	m ³ /h	6.0	10.5	17.2	32.0	35.0	57.0
Cv-Value	gal/min	7.0	12.2	20.0	37.2	40.7	66.3

Dimensions in mm.